

# Scrubdeck



**Facts and technical data on the scrubdeck  
for City Ranger 2260**

# Scrub your city clean

## Remove bird droppings, oil spills, fast food spills etc.

Achieve thorough cleaning of roads, pavements and other surfaces with a scrubdeck mounted on an Egholm utility machine. The scrubdeck is effective on, e.g. concrete pavers, pavements, as well as epoxy, granite and marble coatings.

Thanks to an independent suspension unit and the constant pressure of the brush on the base surface, it follows the contours perfectly. The scrubdeck is designed so that it is mounted close to the A-frame, which ensures a high degree of stability during use.

The low height of the scrubdeck provides the operator with a good view and enables cleaning under benches and around other obstacles. Various types of detergents can be used depending on the task.

### Effective tandem operation

Cleaning is carried out by means of 3 disc brushes under the scrubdeck's front-mounted unit. The remaining dirty

water is then sucked up with a suction nozzle and wiped with a squeegee - both of which are mounted at the rear of the utility machine.

The diameter of the disc brushes is 45 cm and the total cleaning width is 135 cm. The squeegee on the rear unit of the scrubdeck is 140 cm wide and the suction nozzle is 130 cm wide. The suction hose is flexible and has a diameter of 10 cm. Rubber rollers are mounted on both sides in order to protect the suction nozzle against bumps.

### High capacity

The scrubdeck is combined with the collecting tank of the City Ranger 2260 and has an extremely high suction capacity. The collecting tank consists partly of a container for clean water and partly of a container for dirty water.



### Unique scrubdeck for the City Ranger 2260

A cost effective cleaning solution created for municipalities and cleaning contractors within outdoor cleaning.

## Scrubdeck

### - City Ranger 2260



1470 mm



2575 mm

1939 mm  
2060 mm

#### Standard equipment:

- Water supply** Occurs automatically from the A-frame of the utility machine to all 3 brushes in the front-mounted scrubdeck.
- Efficient water system** An innovative water management feature ensures a low water consumption. When the machine does not move, the water is stopped after 1.5 seconds.
- Splash guards** The scrubdeck has 1 splash guard at the front and 2 on each side. All 3 splash guards can be adjusted in height in case of wear or replaced with new ones. The splash guards on the sides also function as side skirts and protect the attachment in the event of a collision.
- Suction nozzle - horizontally** The horizontal placement of the suction nozzle mounted at the rear of the utility machine takes place via a hydraulic raise/lower function from the cabin.
- Suction nozzle - vertically** The vertical placement of the suction nozzle mounted at the rear of the utility machine takes place manually via a knurled knob.
- Squeegee on suction nozzle** The squeegee on the suction nozzle can be adjusted in height in case of wear or replaced with a new one.
- Protection of suction nozzle** In the event of a collision, 2 rubber rollers located on each side of the nozzle will protect the suction nozzle.

#### Technical specifications

##### Dimensions

|                                     |    |             |
|-------------------------------------|----|-------------|
| Length                              | mm | 2575        |
| Width                               | mm | 1470        |
| Height with cabin / roll bar (ROPS) | mm | 1939 / 2060 |

##### Storage dimensions

|                                     |    |             |
|-------------------------------------|----|-------------|
| Length (scrubdeck / suction nozzle) | mm | 910 / 370   |
| Width (scrubdeck / suction nozzle)  | mm | 1350 / 1470 |
| Height (scrubdeck / suction nozzle) | mm | 580 / 924   |

##### Weight

|                                     |    |          |
|-------------------------------------|----|----------|
| Weight (scrubdeck / suction nozzle) | kg | 110 / 50 |
|-------------------------------------|----|----------|

##### Performance

|                                    |                   |       |
|------------------------------------|-------------------|-------|
| Working width                      | mm                | 1350  |
| Tilting angle (+ / -)              |                   | 10    |
| Water tank volume                  | l                 | 100   |
| Number of brushes                  | pcs.              | 3     |
| Brush speed (with 2300 rpm engine) | rpm               | 260   |
| Water flow                         | l/min.            | 0,7   |
| Operating speed (recommended)      | km/h              | 5     |
| Turning circle - kerb to kerb      | mm                | 6000  |
| Theoretical performance            | m <sup>2</sup> /h | 22000 |

##### CE certified according to EU directive

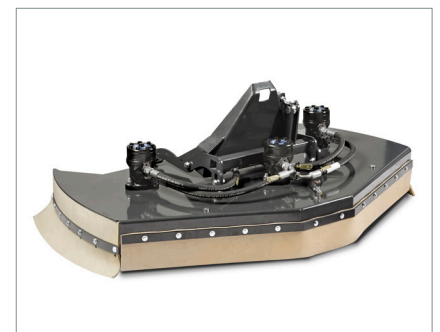
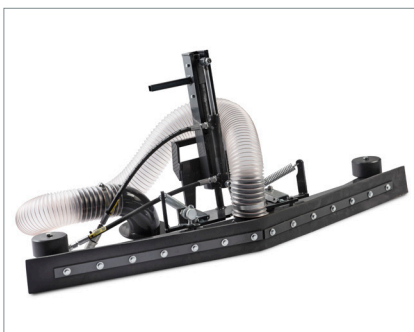

## Honest Work,

Egholm A/S develops, produces and markets utility machines that keep roads, parks and outdoor areas clean and inviting all year round. We supply functional quality machines and attachments to people who do an honest day's work keeping our cities clean and attractive. With special attachments developed for the machines, Egholm machines deliver perfect results no matter the task at hand. Built by craftsmen in Denmark, Egholm machines are in operation in cities and parks all over the world.

## Honest Machines,

Egholm utility machines are developed by people who are passionate about technology and innovation. We listen to the people driving, using and servicing Egholm machines, because they are the true experts. It is our mission to design, build and market utility machines that deliver perfect results in real life. Egholm machines are honest machines - not just because they deliver comfort, safety and strong end results: They are also a sound investment for years to come and give you outstanding return on your investment.

## Honest People,

We want you to think of us as your partner in every single way. And we always insist on reliability, trust and honesty in our partnership with you and with our network of dealers and service partners. We are straightforward and direct in our communication and in our dealings with everyone. Our belief in hard work and unwillingness to compromise helps us deliver the quality for which we are known. And we believe it is reflected by the machines we build for you, as well.

### **Egholm A/S**

Transportvej 27  
7620 Lemvig, Denmark  
T.: +45 97 81 12 05  
[www.egholm.eu](http://www.egholm.eu) - [info@egholm.dk](mailto:info@egholm.dk)

### **Egholm GmbH**

Am Hafen 24  
38112 Braunschweig, Germany  
T.: +49 (0) 531 129 77-0  
[www.egholm.de](http://www.egholm.de) - [info@egholm.de](mailto:info@egholm.de)